



PRODUCT PORTFOLIO

FREESIA/F-5000 VITREOUS CHINA URINAL

Falcon Waterfree® urinal systems reduce water and sewer costs, lower maintenance and repair bills, and create more hygienic, odor-free restrooms. Our patented three part system, including vitreous china bowl, sloped housing and cartridge, eliminates the need for water, conserving up to an average of 40,000 gallons (150,000 liters) or more of water per urinal each year.

The Falcon Freesia or F-5000 waterfree urinal is constructed of vitreous china and is a wall hung, wall outlet unit. It is the smallest Falcon Waterfree urinal, and ideal for installations with space limitations. The stylish design of the Freesia combines an attractive appearance with functionality and efficiency. The Freesia/F-5000 meets ANSI/ASME A112.19.19-2006 for vitreous china non-water urinals and is CSA approved. It also complies with the American Disabilities Act guidelines and ANSI A117.1 for accessible and usable buildings and facilities and with the International Plumbing Code, National Standard Plumbing Code and Uniform Plumbing Code requirements.

BENEFITS

- Uses no water for operation
- Five times less bacteria than flush urinals
- Reduced water and sewer costs
- No costly flush valve or sensor repairs
- No replacement sealant costs
- Provides downhill flow, helps reduce clogs
- Minimal care and easy cleaning
- Improved hygiene and safety
- Dual barrier protection
- Odor-free
- Ideal for limited space

FEATURES

- Touch-free operation
- Mechanical-free design
- Patented locking cartridge
- Maintenance-free cartridge
- Smooth, non-porous surface
- Vitreous china bowl
- Small size



“Falcon Waterfree urinals are predicted to be 500 times more effective against back migration of sewer gases as compared to conventional P-trap water barriers.”

-Michael Hoffman, Ph. D
California Institute of Technology

SYSTEM INCLUDES

- Vitreous china bowl
- Installed cartridge housing
- Cartridge kit*
- Exclusive pipe-in-pipe technology*
- One-piece wall bracket with anchors*
- Drain line test cap*
- Uni-coupler*
- Installation Instructions

CARTRIDGE KIT* INCLUDES

- One sealed cartridge
- Pre-measured liquid sealant pack
- Installation key
- Disposal bag
- Plastic gloves
- Instruction sheet

*Availability varies by region

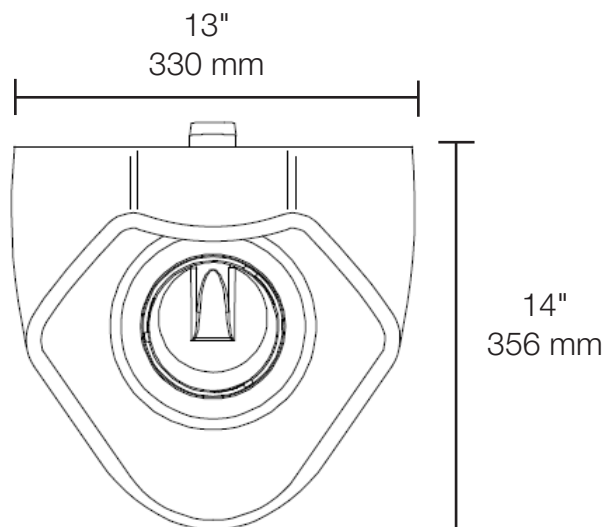
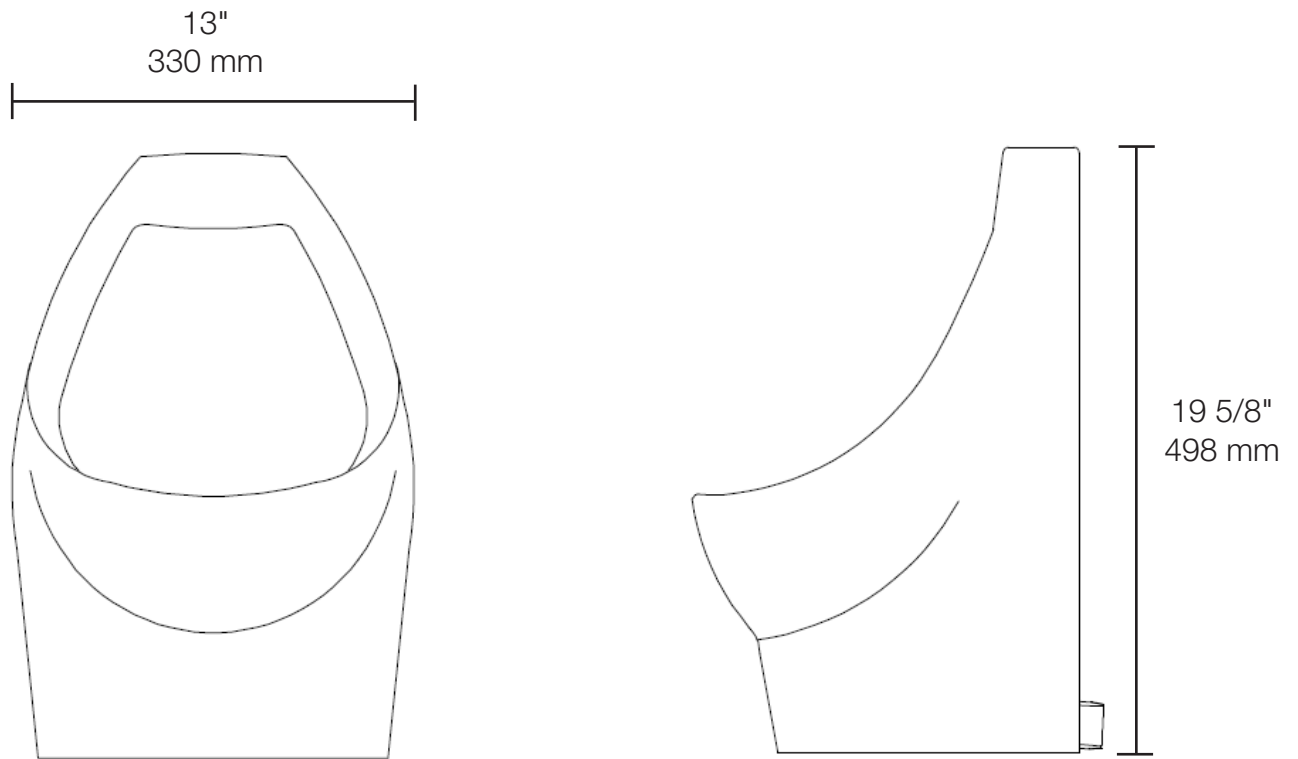

The dimensions are for informational purposes only. For specific rough-in dimensions and weights, please refer to specification sheets available at www.FalconWaterfree.com or contact us directly.

WARNING not recommended for installation on copper drain, waste and vent systems.